

Europäisches Patentamt  
 European Patent Office  
 Office européen des brevets



Publication number: 0 436 887 A1

12

EUROPEAN PATENT APPLICATION

21 Application number: 90124608.2

51 Int. Cl.<sup>5</sup>: G05B 19/18

22 Date of filing: 18.12.90

30 Priority: 08.01.90 JP 1293/90

43 Date of publication of application:  
 17.07.91 Bulletin 91/29

64 Designated Contracting States:  
 DE GB

71 Applicant: MITSUBISHI DENKI KABUSHIKI  
 KAISHA  
 2-3, Marunouchi 2-chome Chiyoda-ku  
 Tokyo 100(JP)

72 Inventor: Imanishi, Kazuo, c/o Mitsubishi  
 Denki K.K.  
 Nagoya Works, 1-14, Yadamiami 5-chome  
 Higashi-ku, Nagoya-shi, Aichi(JP)

74 Representative: Sajda, Wolf E., Dipl.-Phys. et  
 al  
 MEISSNER, BOLTE & PARTNER  
 Widenmayerstrasse 48 Postfach 86 06 24  
 W-8000 München 86(DE)

54 A numerical control unit.

57 A numerical control unit is provided for controlling the movement of a machine element (19) or workpiece with respect to a movable machine tool device (9), such as a lathe, milling machine or drum press, in response to input control information as well as detected machine tool position and speed information. A pulse generation system (10), respon-

sive to machine tool movement, provides pulses to registers (11,14) that store position and speed information. Synchronized control of the machine tool (9) and machine element (19) or workpiece movement on the basis of both position and speed parameters is conducted under processor control (17).

EP 0 436 887 A1

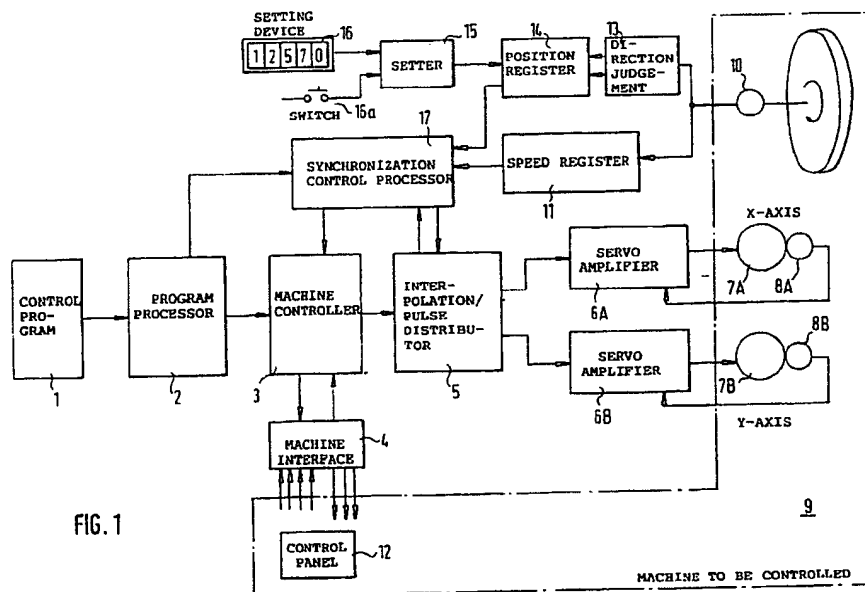

FIG. 1

## A NUMERICAL CONTROL UNIT

The present invention relates to a numerical control unit for performing drive control of a movable part of a machine by means of a control program. In particular, it relates to the coordination of the motions of a numerically controlled machine tool and an associated machine element.

Figure 7 is a functional block diagram illustrating a conventional numerical control unit. In Figure 7, a control program 1, organized as blocks of instructions, is provided to a program processor 2 which will read the control program 1, decode its data, and create control command data. A machine controller 3 receives control command data from the program processor 2 and is in communication with an interface 4 to the machine 9 (indicated schematically by dashed lines) that is being controlled. The controller 3 is operative to control start-up of the program processor 2 in accordance with a control signal from the machine interface 4, receive detected rotational speed data, add execution speed data to the control command data, and generate output command data. Also connected to the machine controller for receiving output command data from the controller is an interpolation/pulse distributor 5 for distributing direction signals for directing movement along each of two orthogonal axes, in accordance with the control command data. The direction signals are received by X-axis and Y-axis servo amplifiers 6A and 6B, respectively, for driving corresponding servo motors 7A and 7B according to the control command data. The linear position of the machine 9 is identified by an X-axis detector (pulse generator) 8A and a Y-axis detector (pulse generator) 8B and the position information is fed back to the corresponding servo amplifier 6A, 6B.

The system also includes another machine (not shown) which is not controlled by the control program 1, but which may also operate in some fashion on the workpiece. Information on the operation of this machine, for example the speed with which a part of the machine moves in the system, is identified by a detector (pulse generator) 10, which produces pulses in relation to the movement of that device by a predetermined distance or angle of rotation in a given time span. The detected speed value is placed in a speed register 11 for subsequent reading by the machine controller 3. A control panel 12 is located on the machine 9 for controlling operation of the machine 9.

In operation, when a machine operation START signal is entered into the machine controller 3 through the machine interface 4, the machine controller 3 causes the program processor 2 to begin reading the control program 1. the program proces-

sor 2 reads the control program 1 in order on a block-by-block basis, starting at the beginning thereof, and decodes the program instructions. The program processor 2 then converts the decoded control program 1 into an integral processing data structure, creates control command data, and outputs that control command data to the machine controller 3. In response to the control command data, the controller 3 generates machine ON-OFF control signals that are output to the machine 9 to be controlled, via the machine interface 4. The controller 3 also generates axis control data that is output to the interpolation/pulse distributor 5 as X-axis and Y-axis control commands. The axis control commands are limited by established execution control speeds, based on execution speed data (override) sent by the external control panel 12 via the machine interface 4. Thus, the machine controller 3 is capable of executing the entire numerical control function for machine 9 in accordance with operation control signals from a processor or an operator.

The interpolation/pulse distributor 5 may employ linear or circular interpolation and can control acceleration/deceleration in accordance with the axis control commands and the execution speed data. the interpolation/pulse distributor 5 distributes and outputs control signals to the servo amplifiers 6A and 6B. The servo amplifiers direct machine movement along the X- and Y-axes, according to the control program 1, by controlling the positions and speeds of the servo motors 7A, 7B in accordance with the control signals of the corresponding axes and the feedback signals generated by the corresponding detectors 8A and 8B.

In addition to the aforementioned general numerical control operation, control can be carried out in synchronism with movement of the external machine element or system. The speed register 11, which stores a detection signal (pulse train signal) from the detector 10 in the external system, reads the pulse train signal at predetermined intervals and stores the read signal serially as speed data. If the control program 1 contains an instruction for the conduct of a synchronized machine 9/external machine operation, the program processor 2 decodes that instruction and provides an appropriate command to the machine controller 3. When synchronized control is to be performed, the machine controller 3 reads the speed data of the speed register 11 serially at predetermined intervals, calculates the appropriate execution speeds for the axis control commands in accordance with the most recent speed data, and outputs the appropriate control commands to the interpolation/pulse

distributor 5. Through the above operation, control of the machine 9, synchronized with movement in the external system, can be obtained.

However, the conventional numerical control unit will only allow speed synchronization control movements in the external system. For example, the conventional unit can perform only limited synchronized machining of workpieces requiring position control, for example a threading operation on a lathe or a tapping operation on a milling machine. Specifically, the conventional unit cannot be used with a device requiring both position synchronization control and speed synchronization control.

The object of the present invention is to overcome the disadvantages in the conventional system by providing a numerical control unit which will permit position synchronization control in addition to speed synchronization control.

According to the present invention there is provided a numerical control unit operative in response to control program commands for controlling movement of a first device, operating in a first control system, with respect to a second device that is movable at selected speeds and between selected positions in a second control system not controlled by the numerical control unit, comprising speed information storing means for storing and updating speed information on the second device and synchronization control means for performing synchronization control of the first device with respect to the second device, and characterised in that position information storing means is provided for storing and updating position information on the second device, and in that the synchronization control means operates in accordance with synchronization commands and the position and speed information stored in the information storing means to perform synchronization control of the movement of the first device with respect to movements of the second device.

In the invention, if a command from the control program designates speed synchronization, the synchronization control processor reads the speed data for the driven object in the workpiece system from the speed information storage and controls the machine execution speed in order to perform speed synchronization. If the control program has commanded the implementation of position synchronization, the synchronization control processor serially reads the data for the driven object in the external system from the position information storage, compares that data with the command synchronization position, and, on identifying the synchronization position, performs start/stop control of the driver for the machine to be numerically controlled. If both position and speed synchronization are commanded, the above two types of control are processed in parallel to perform position/speed

synchronization.

The present invention will now be described by way of example with reference to the accompanying drawings, in which:

Figure 1 is a block diagram of a numerical control unit according to a preferred embodiment of the present invention;

Figure 1A illustrates an external system, here a rotary press, with which the numerically controlled apparatus of the invention is synchronously operated;

Figure 2A illustrates the rotational position of a rotary crank of a press machine and Figure 2B a variation in the vertical position of a die during a pressing operation as the crank rotates;

Figure 3 illustrates an example of a control program usable with the embodiment shown in Figure 1, together with a schematic diagram of the numerically controlled machine;

Figure 4 illustrates the relationship between crank position and X-, Y- axis control commands executed according to the program of Figure 3; Figure 4A illustrates the synchronization control processor of Fig. 1 in greater detail;

Figure 5 is a processing flowchart for the synchronization control processor used according to the embodiment in Figures 1 and 4A;

Figure 6 is a processing timing chart illustrating speed synchronization control according to the embodiment in Figure 1; and

Figure 7 is a block diagram of a conventional numerical control unit.

In the drawings, the same reference numerals are used throughout to designate like or corresponding parts.

A preferred embodiment of the present invention will now be described using, as an example, workpiece transfer control for a rotary press. Referring to Figure 1, a program 1, stored in memory, on disk, tape or the like, is accessible by a program processor 2, which is connected to a machine controller 3 and a synchronization control processor 17, to be described later. The controller 3 communicates with the processor 17, a machine interface 4, and an interpolation/pulse distributor 5. As previously described with respect to Figure 7, servo amplifiers 6A, 6B receive pulse signals from pulse distribution unit 5 and drive X-axis and Y-axis servo motors 7A and 7B, respectively, using feedback from detectors 8A, 8B for control of the operation of machine 9, which is a press feeder for example. A detector (pulse generator) 10 is directly connected to a driven rotary element of the press, and a speed register 11 detects the speed of rotation of this element. A machine control panel 12 inputs control information for the machine. To this construction the present invention further adds a direction judging device 13 for judging the direction

of the detector signal pulse (a two-phase signal). A position register 14 accumulates positive and negative-direction pulses output by the direction judging device 13, and a setter 15 presets position data in the position register 14. The system is completed by a position input device 16 and a reset (clear to zero) switch 16A. The synchronization control processor 17 carries out synchronization control in accordance with data from the speed register 11 and the position register 14 in response to synchronization commands originating from the control program 1.

Figure 1A illustrates one example of an external (non-numerically controlled) system, here a rotary press. The press includes a crank 21 which raises and lowers die 20 for, for example, punching apertures in successive workpieces. At the end of the crank resides the detector 10, which generates pulses in accordance with rotary movement of the crank. The crank and thus the attached die are driven by a motor 22, which is controlled independently of the numerical control (NC) system and the machine 9.

The numerically controlled machine 9 in our example includes a workpiece carry-in and carry-out device 19, including an arm with an attached clamp movable in an X-Y plane. The movement of the arm is controlled by the servo motors 7A, 7B also shown in Figure 1. In operation, the arm will be caused to grasp the workpieces arriving from a carry-in conveyor 24, move the workpieces into position for punching on the punch, and after punching, retrieve the workpieces and deliver them to a carry-out conveyor 26. Also shown in Figure 1A are the servo amplifiers 6A and 6B, and the remainder of the NC controller, which is shown in more detail in Figure 1.

Operation of the preferred embodiment is described with reference to Figures 1, 1A, 2A and 2B. Figure 2A illustrates the variable angular position of the rotary crank 21 of the press and Figure 2B illustrates the relative position of the die 20 as the crank 21 rotates. Referring again to Figure 1, the position register 14 should be reset by the setter 15 so as to be zeroed at a 0° position (top dead centre) of the crank 21. Setting device 16 indicates the value (usually 360° in this example) at which the setter 15 should perform this function. At this position, the die 20 is located at the top dead centre. When the crank 21 rotates, the detector 10 (which may be a synchronous decoder) will generate pulses, e.g., one for each predetermined increment of rotation, and provide them via the direction judgement circuit 13 to the position register 14, which serially accumulates (increments and decrements) a pulse total as an indication of current position (current angular position of the crank 21, which is related to the current height of the die 20).

As the crank 21 rotates, the position of the die 20 varies between top dead centre and bottom dead centre, in a reciprocal manner. The position register 14 is set to 0 by the setter 15 when the angular position reaches 360° (0°) at each rotation. By the above operation, the current rotational position of the rotary crank is stored and serially updated in the position register 14.

Figure 3 shows an example of a control program illustrating the operation of the present invention. In Figure 3, a schematic diagram of the machine arrangement of Figure 1A is shown in conjunction with a typical NC program. The program illustrated is designed to cause the arm to pick up a workpiece from the carry-in conveyor side, deliver the workpiece to the press, and pick up the pressed workpiece and deliver it to the side of the carry-out conveyor.

Step 1 of the program is a G00 instruction, which commands high speed linear movement. Here, the instruction requires movement in the -Y direction, corresponding to movement "1" shown in Figure 3 (movement to the left to the carry-in station to pick up a workpiece). Step 2 commands operation of the clamp, so that the work will be grasped. Step 3 instructs speed synchronization (G95) as well as positional synchronization (G101) of the next movement with the speed and position of the press, specifically the speed of rotation of the crank 21 and the position of the crank 21, which translates as the position of the die 20. In step 3, the arm with its clamped workpiece will travel along path "2" shown in the upper part of the figure at a synchronised speed F10 (explained hereinafter) beginning at a time when the crank 21 reaches a rotary position of 30° (determined by instruction "R30") from top dead centre. As a result, the workpiece will be delivered to the press as the die 20 is moving down toward the pressing position. It can be easily seen that it is necessary in cases such as the present that the operation of the arm be synchronized positionally with the location of the die 10, as otherwise the workpiece may be inserted too late and may interfere with die movement and/or damage the die 20. The speed of the press and thus the die 20 is not controlled by the numerical controller, and thus it is necessary to adapt the numerical control of the arm to the actual conditions (i.e. the operational speed) of the press, which may be variable. To this end, the speed of operation of the arm is determined by the speed of operation of the press in those cases where speed synchronization is commanded, and the start of operation of the arm is tied in to the position of the crank 21 in cases where positional synchronization is commanded.

In step 4, the workpiece is unclamped, and thus is positioned within the press. Step 5 com-

mands the retraction of the arm away from the press, along path "3" shown in the figure, with speed synchronization (G95) only, at speed F20.

After pressing, movement is instructed along path "4" in the figure to retrieve the finished workpiece (step 6). In this example, this operation is also performed with speed and positional synchronization, so that the movement commences when the crank angle has reached the 190° position (just past bottom dead centre), and precedes at synchronized speed F10. In step 7, the workpiece is clamped, and in step 8, travel along path "5" is instructed, at synchronized speed F20, to deliver the workpiece to the carry-out conveyor. Finally, in steps 9 - 11, the workpiece is unclamped, releasing the workpiece, the arm moves to the left at high speed back to the start position, and the program loops back (M99) to the start position (step 1).

The "synchronized speeds" referred to above may be explained as follows. The number which follows "F" in the speed instruction indicates the amount of X-Y plane travel per unit pulse of the detector 10, in millimetres. Therefore, the "F10" instruction sets the arm movement speed at 10mm per pulse of the detector 10. Since each detector pulse corresponds to a certain angular movement of the crank, the speed of the arm is synchronized with the speed of the crank, and thus the movement of the die. Figure 4 shows the X/Y axis movement of the numerically controlled arm, in synchronization with the angular position of the crank, for the command sequence of Figure 3.

In Figure 4, the circled numbers correspond to the movements indicated in Figure 3. By way of example, it can be seen from Figure 4 that movement along path "4" (corresponding to step 6 in Figure 3) is begun at a point corresponding to a crank position of 190°. Only an X-axis movement is shown here because step 6 involves only X-axis movement. This movement is followed in Figure 4 by joint X and Y axis movement along path 5, as instructed by step 8 of the program of Figure 3. This is followed by movement along path "6", in the "Y" direction only, as commanded by step 10 of the program. It will be noted from Figure 4 that the speed of movement of step 6 is greater than that of steps 4 or 5 (the height of the trapezoid is indicative of speed) because the step 6 command is a high speed traverse (G00). The movement designators are trapezoidal in Figure 4 to illustrate the acceleration and deceleration at the beginning and the end of each movement.

Figure 4A illustrates the synchronization control processor ("SCP") 17 in greater detail. This device is responsible for acting on the synchronization commands in the user program to coordinate the synchronization function. The SCP includes a programmed position reader 60 which detects a G101

(position synchronization) instruction from the program processor 2, and reads the designated position value (contained in the "R" instruction of the program) and stops operation of the interpolation pulse distributor 5 in response. This latter action prevents the current command block (X-Y movement) from being executed immediately. A synchronization position detector 61 reads the current position of the crank 21 from the position register 14, and operates to start the interpolation pulse distributor 5 when the position read from register 14 corresponds to the program-designated position value, so that the distributor 5 is instructed to execute the command block. It is thus possible to start the carry-in operation or the carry-out operation immediately once the crank angle of the press corresponds to the program commanded synchronous position.

A programmed feed speed reader 62 reads the programmed synchronization feed speed (from the "F" instruction in the program) in response to a G95 (speed synchronization) command, and starts the operation of a processor 63 which will calculate the actual feed speed of the arm from the "F" value and the current speed of the crank, the latter being read from register 11. The calculated value is then sent to the machine controller 3. Reading and computation take place within a very short interval (indicated in Figure 6) so that speed control will closely follow fluctuations in the speed of the external apparatus, here, the crank speed.

Figure 5 is a flowchart illustrating the operation of the synchronization control processor 17 in effecting the above described functions. Processing of an external position/speed control routine, for implementing the synchronization commands (G95, G101) provided by the program processor 2, is performed at a predetermined interval of several milliseconds. In the absence of a speed synchronization command G95 at step 101, processing is carried out to determine the presence of a position synchronization command (G101) at step 111. If neither is present, the routine repeats. Assuming command 101 is present, the synchronization position data specified by the program (in the "R" instruction) and present position data stored in position register 14 are read at steps 112, 113. The present position is updated every cycle and is used for a determination of whether the synchronization position has been reached at step 114. If the data obtained does not indicate that the crank 21 is at the synchronization position, implementation is held off and the flow is repeated. When the data indicates that the crank is at the synchronization position, a start command is given to the interpolation/pulse distributor 5 at step 115, and position synchronization is thus carried out.

If there is a synchronization speed command

(G95), the flow proceeds from step 101 to step 102, where the presence of the position synchronization command G101 is determined. If the G101 command is not present, the program proceeds to step 107 where the programmed synchronization speed is read ( from the "F" instruction), followed by a reading of the crank speed data stored in speed register 11. The correct arm speed is calculated by the processor 63 in step 109 using the read crank speed value and the mm/pulse value obtained from the "F" instruction, and the speed data is output to the machine controller 3 in step 110. This speed value will be valid until the, next loop through the program, at which time a new speed value may be calculated, depending on the detected speed of the crank at that time.

In the event that a position synchronization command G101 is present in addition to a speed synchronization command G95, the program proceeds from step 102 to step 103, where the synchronization position is read, followed by step 104 where the position register 14 is read. At step 105, the processor determines whether the synchronization position has been reached. If not, the program proceeds to step 107 for calculation of the speed data. The programmed synchronization speed will be read (step 107), the speed register read (step 108), and the synchronization speed of the arm will be calculated (step 109) with the speed data being output to the machine controller at step 110. If the synchronization position has been reached at step 105, the interpolation/pulse distribution circuit 5 will receive a START directive from processor 17 to start the operation of the servo amplifiers at step 106, prior to proceeding to speed calculation and control steps 107-110.

In short, the synchronization speed is calculated and output to the machine controller every cycle so long as a speed synchronization command G95 is present, but the position synchronization operation proceeds only when the crank is at the synchronization position. When both position and speed synchronization control are conducted, the processing of both is executed in one cycle, following the left side of the Fig. 5 flowchart.

Figure 6 is a processing timing chart illustrating the speed synchronization of the synchronization control processor 17 and the machine controller 3.

The figure shows the timing involved in reading the position information stored in the register 11 and/or 14 and then performing processing based on the read data. A reference timing block is shown in line A, the period of which is generally less than 20ms. External position and/or speed reading/processing is conducted starting at the beginning of one reference block as shown in line B. During a portion of the reference block, a speed synchronization operation/calculation is conducted,

as indicated by the hatched block portion. Following termination of that operation, the machine controller receives the output data and conducts a speed synchronization control operation in which a calculated value is output to the interpolation/pulse distributor 5, as seen in time line C, starting at the beginning of the next reference block.

It will be appreciated that instead of commanding only a start position for the position synchronization control as in the foregoing embodiment, both start position and a stop position may be indicated in the control program and these positions may be discriminated by the synchronization control processor 17.

It will further be appreciated that a start may be effected at any time, as necessary, and only the stop position need be synchronized with the external position.

It will further be appreciated that in addition to the aforementioned start/stop control by position synchronization, the external position data and a numerically controlled coordinate position may be overlapped with each other to enable more fine control.

It will be apparent that the invention, as described above, permits a numerical control unit to provide of speed synchronization control, position synchronization control and speed/position synchronization control with a driven object, particularly a machine element operating in a control system other than that which is numerically controlled.

It also will be apparent that the external system need not be limited to a system operating on a workpiece, but may comprise any second machine operative with the numerically controlled system.

## Claims

1. A numerical control unit operative in response to control program commands for controlling movement of a first device (9), operating in a first control system, with respect to a second device (20,21) that is movable at selected speeds and between selected positions in a second control system not controlled by the numerical control unit, comprising speed information storing means (11) for storing and updating speed information on the second device (20,21) and synchronization control means (17) for performing synchronization control of the first device (9) with respect to the second device (20,21), and characterised in that position information storing means (14) is provided for storing and updating position information on the second device (20,21), and in that the synchronization control means (17) operates in accordance with synchronization commands

- and the position and speed information stored in the information storing means (14) to perform synchronization control of the movement of the first device (9) with respect to movements of the second device (20,21). 5
2. A unit as claimed in Claim 1, characterised in that a means (10) for detecting the speed and position of at least one element (21) of the second device is provided to generate signals for output to the storing means (11,14). 10
  3. A unit as claimed in Claim 2, characterised in that the means (10) for detecting operates to judge a relative direction of movement of the element (21) of the second device (20,21). 15
  4. A unit as claimed in Claim 2 or Claim 3, characterised in that the position and speed information storing means (11,14) are responsive to pulses and in that the detecting means (10) further comprises pulse generating means responsive to the movement of the element (21) of said second device (20,21). 20
  5. A unit as claimed in any one of Claims 1 to 4, characterised in that the position information storing means (14) is selectively resettable at a reference position. 25
  6. A method of controlling a numerical control unit operative in response to control program commands for controlling movement of a first device (9), operating in a first control system, with respect to a second device (20,21) that is movable in a second control system and not controlled by the numerical control unit, comprising detecting the speed of at least one element (21) of the second device (20,21), and storing data identifying the detected speed, and characterised in that the position of at least one element (21) of the second device (20,21) is also detected and stored, and in that all the stored data is processed and the movement of the first device (9) is controlled in synchronism with the movement of the second device (20,21) 30 35 40 45
  7. A method as claimed in Claim 6, characterised in that the processing of either the speed data or the position data is selected by control program commands. 50
  8. A numerical controller operative in response to control program commands for controlling movement of a first device (9) in synchronism with a second device (20,21) not controlled by said numerical controller, comprising means 55
- (10) for detecting the speed of at least one first element (20,21) of the second device (20,21); and means (17) for processing speed synchronization commands in the control program command, comprising means (62,63) for interpreting a speed synchronization command and for controlling the speed of at least one element (19) of the first device (9) in synchronism with the speed of the first element (21) of the second device (20,21); and characterised in that means (10) for detecting the position of at least one second element (21) of the second device (20,21) is provided together with means (17) for processing position synchronization commands, which comprises means (60,61) for interpreting a position synchronization command and for controlling the movement of at least one element (19) of the first device (9) in accordance with the position of the second element (21) of the second device (20,21).
9. A controller as claimed in Claim 8, characterised in that the first and second elements (21) are the same element. 7

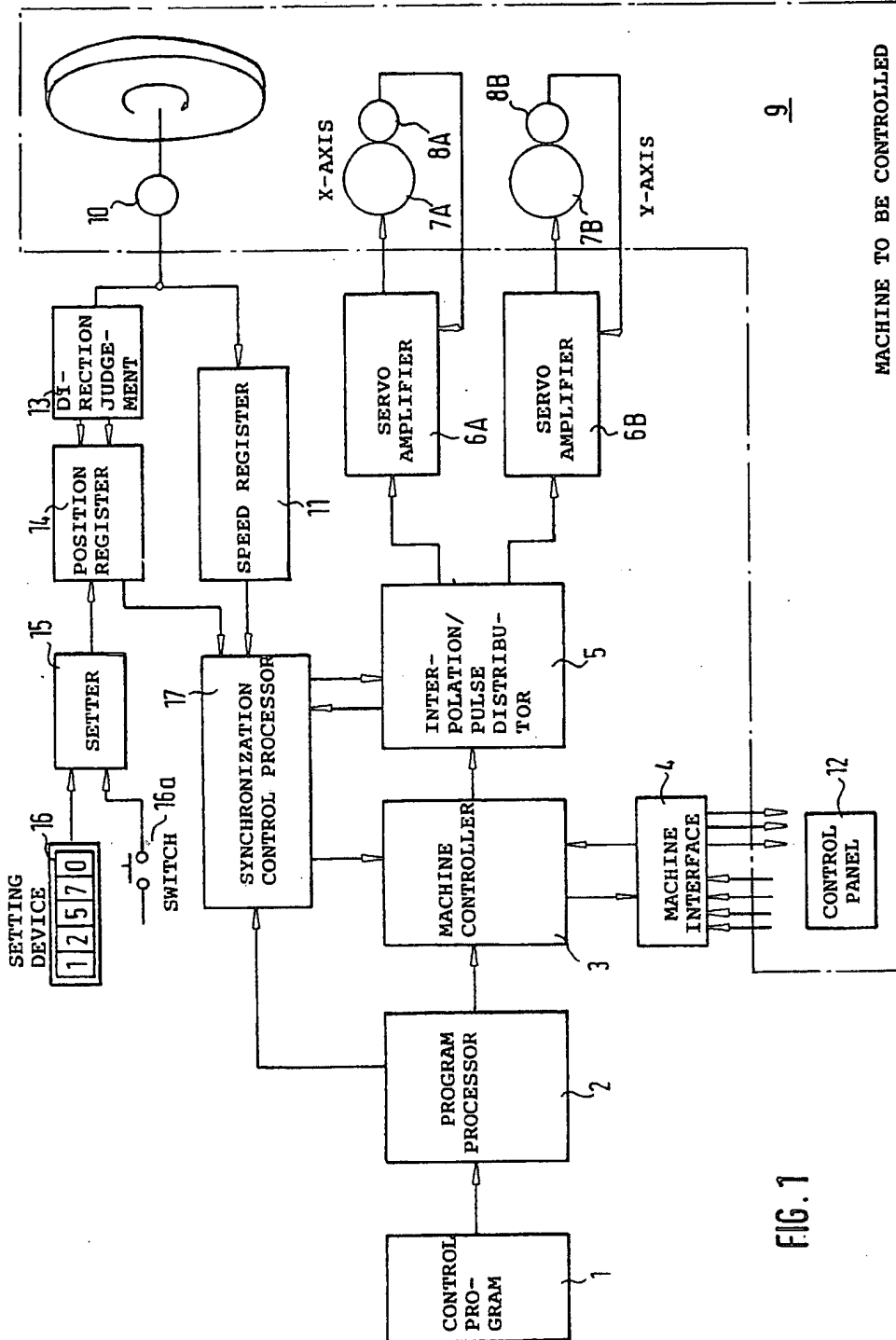
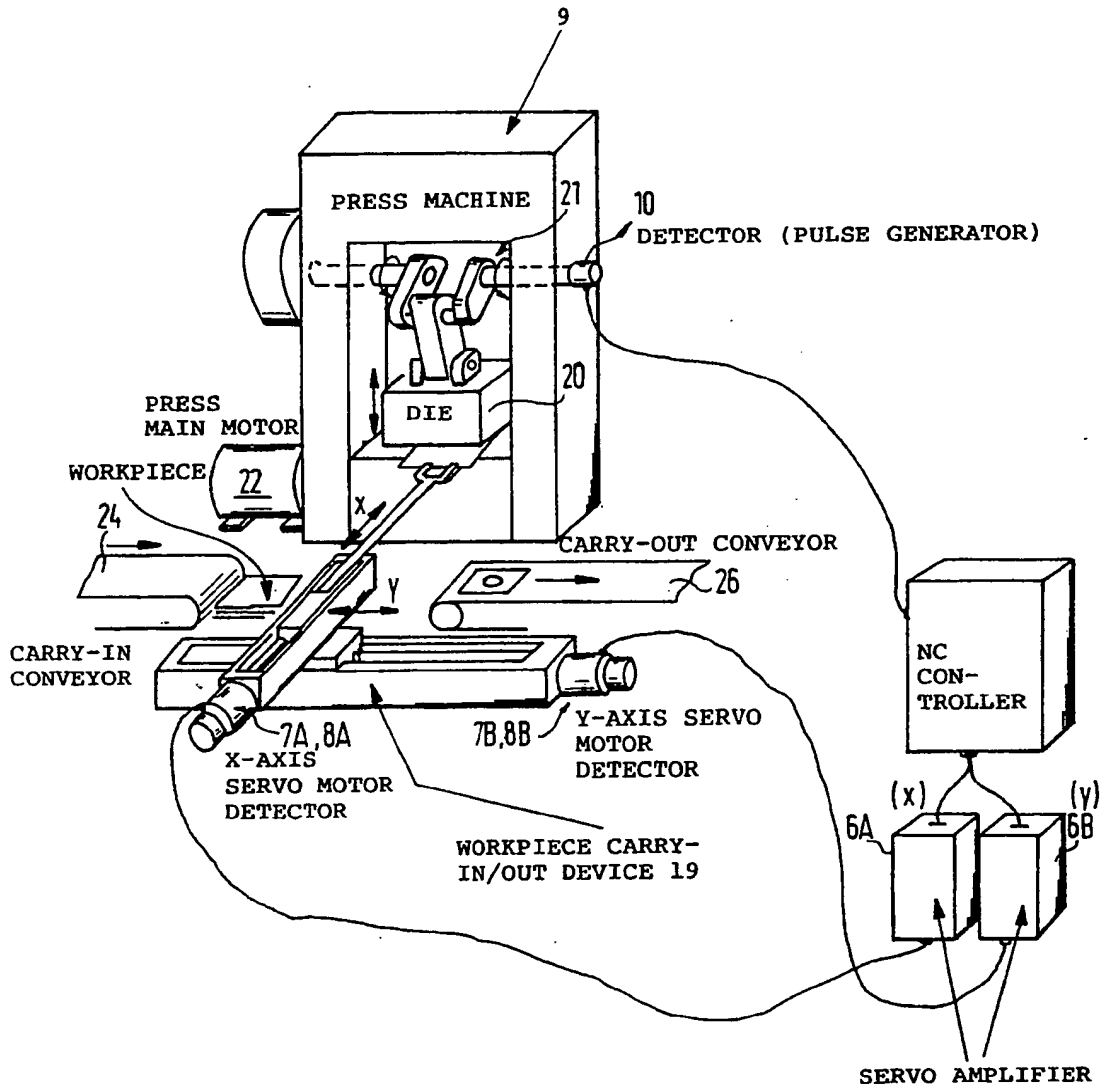
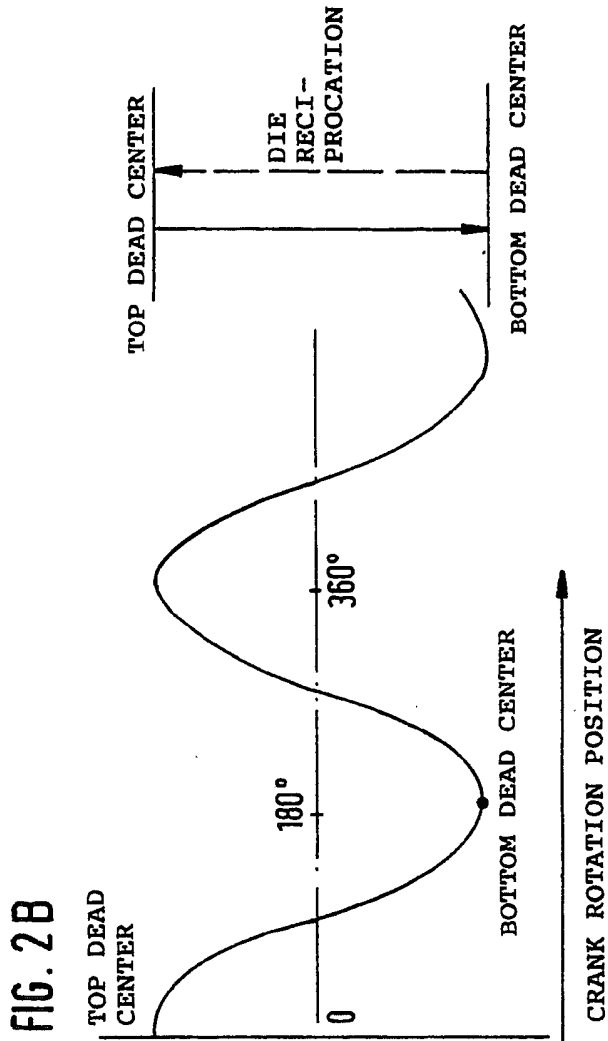
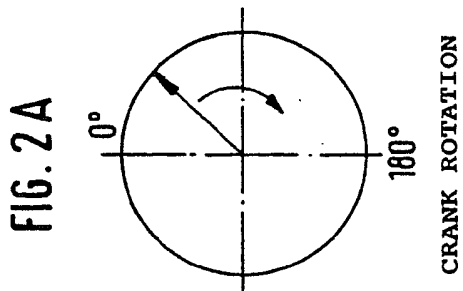

FIG. 1



FIG. 1A





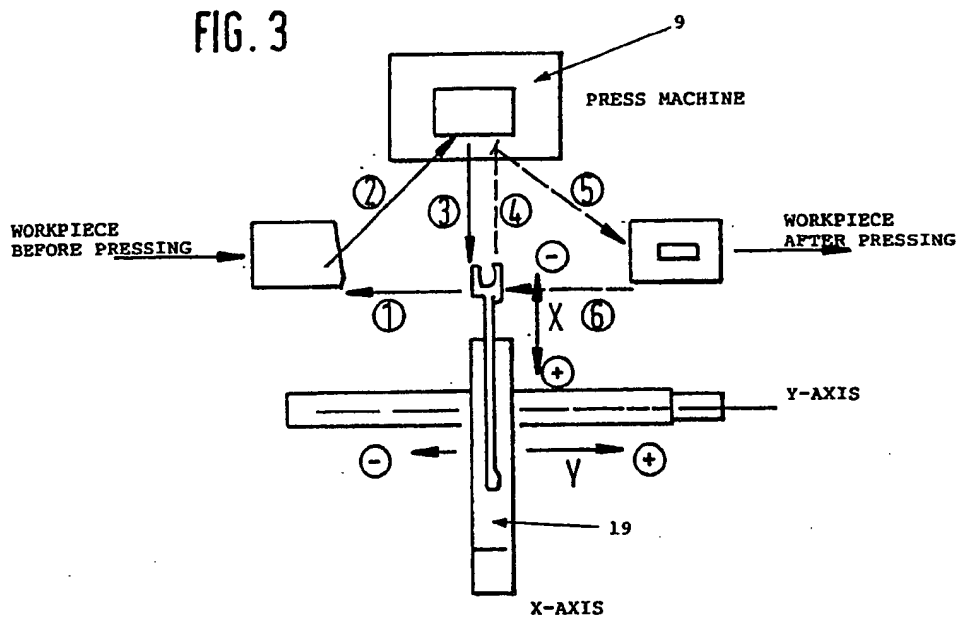

<u>PROGRAM STEP</u>	<u>COMMENT</u>
N01 GOOY-200.;	TRAVEL ①
N02 M15;	CLAMP WORKPIECE
N03 G101G95X-300.Y200.R30.F10.;	TRAVEL ②
N04 M16;	SET WORKPIECE ON PRESS
N05 G95X300.F20.;	TRAVEL ③
N06 G101G95X-300.R190.F10.;	TRAVEL ④
N07 M15;	CLAMP WORKPIECE
N08 G95X300.Y200.F20.;	TRAVEL ⑤
N09 M16	UNCLAMP WORKPIECE
N10 GOOY-200.;	TRAVEL ⑥
N11 M99;	RETURN TO THE PROGRAM START POSITION

FIG. 4

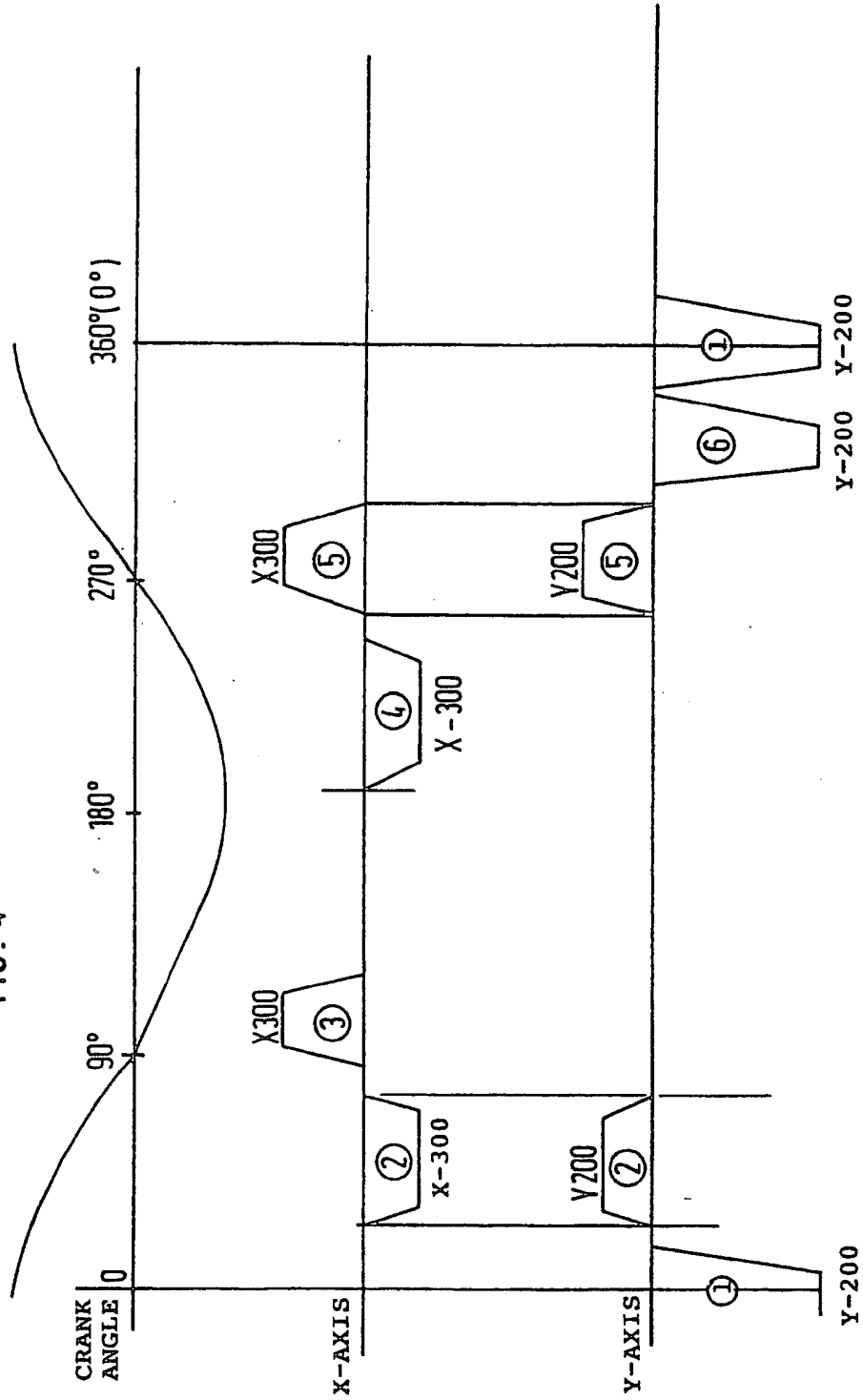

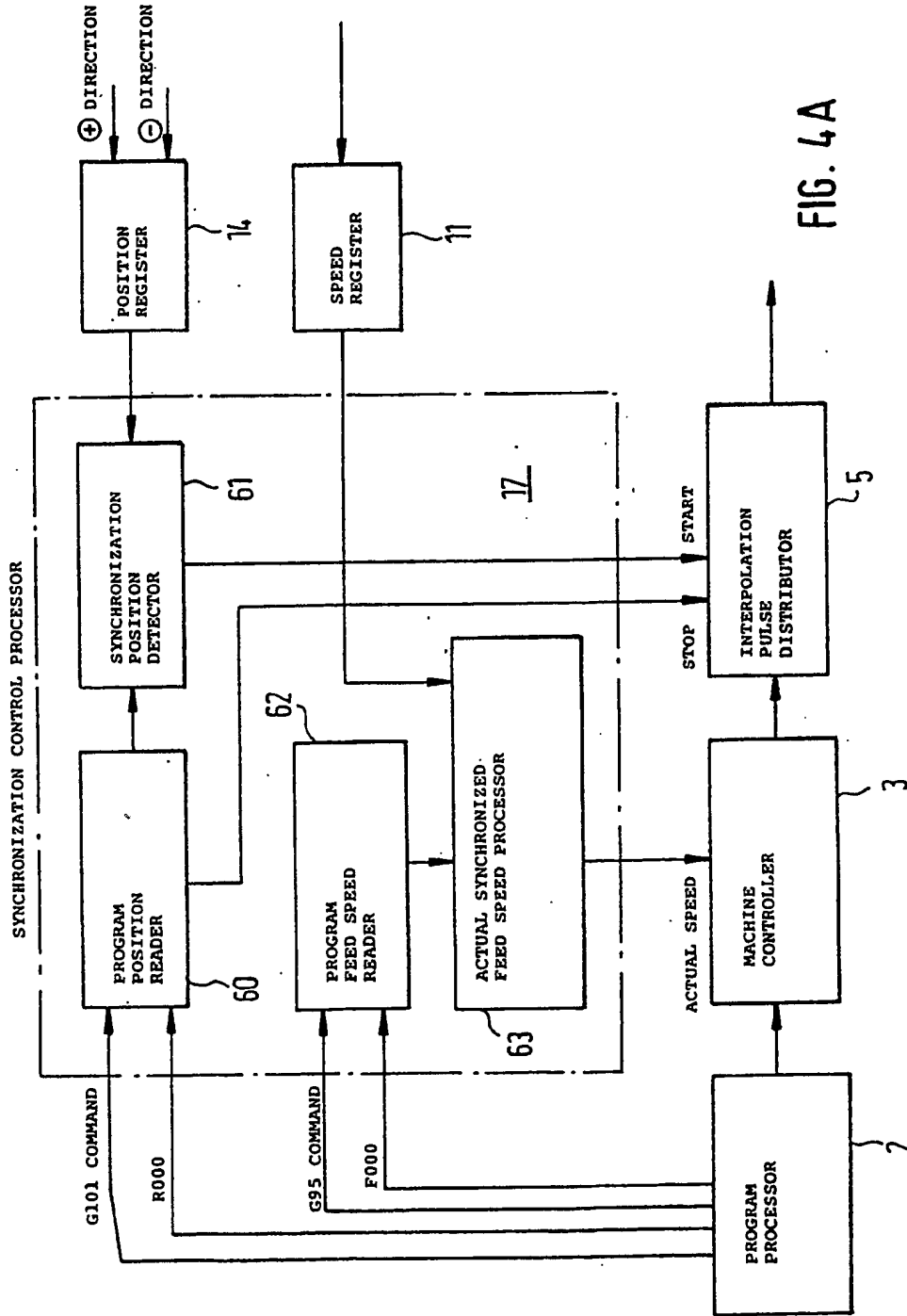

FIG. 5

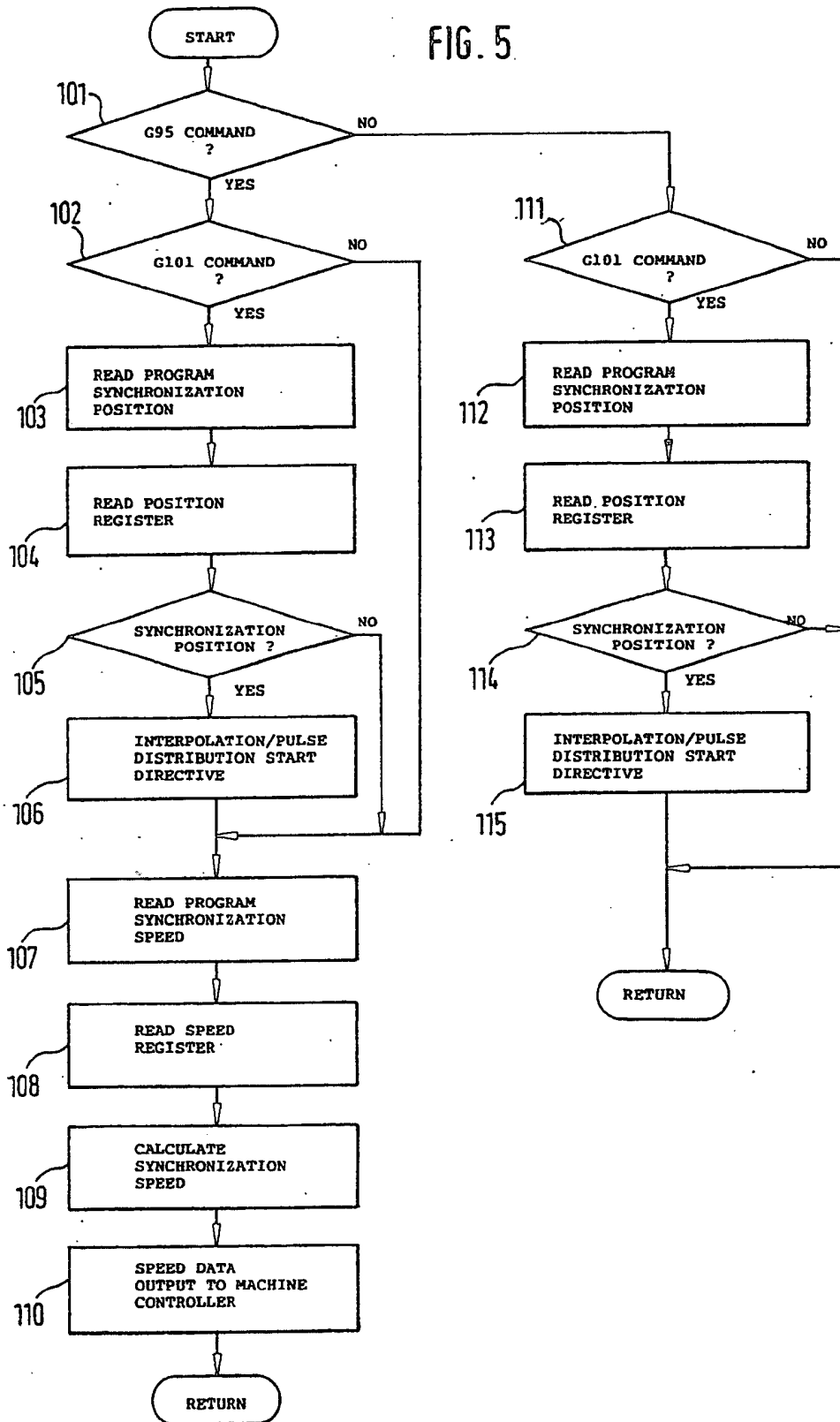

FIG. 6

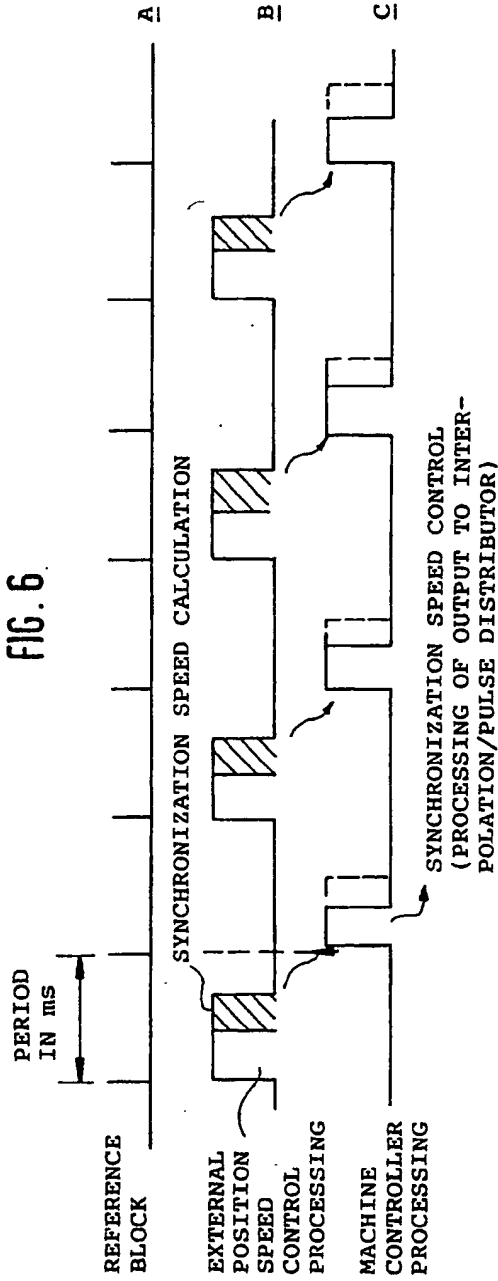
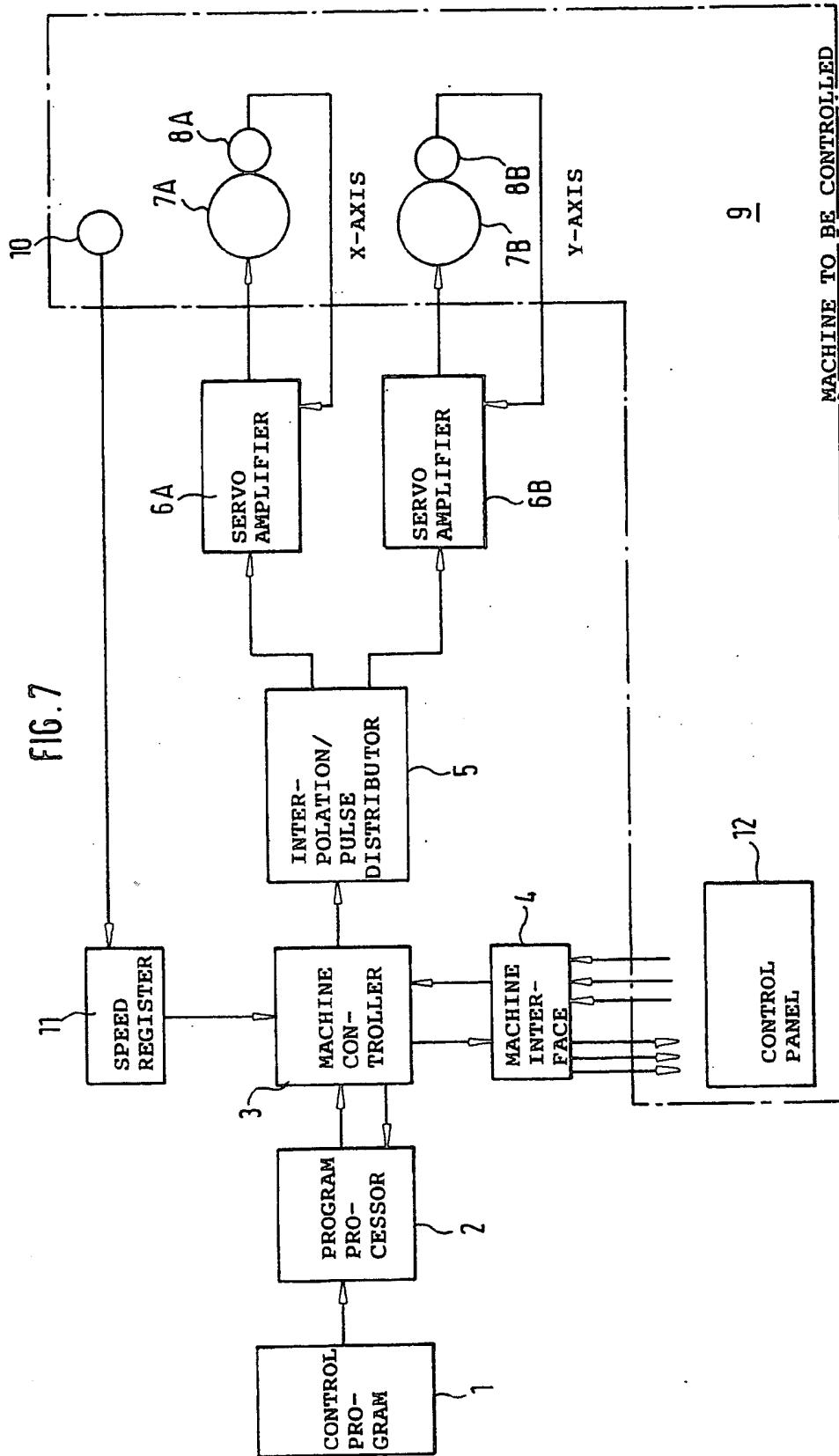

FIG. 7







DOCUMENTS CONSIDERED TO BE RELEVANT			EP 90124608.2
Category	Citation of document with indication, where appropriate, of relevant passages	Relevant to claim	CLASSIFICATION OF THE APPLICATION (Int. Cl.5)
A	<u>DE - A1 - 3 229 988</u> (AMADA CO. LTD.) * Totality * --	1-7	G 05 B 19/18
A	<u>US - A - 4 794 311</u> (KIYA et al.) * Column 1, line 36 - column 2, line 20; fig. 1,3,5,7 * --	1-7	
A	<u>DE - A1 - 2 910 399</u> (L. SCHULER GMBH) * Page 7, line 5, page 8, line 32; fig. 2 * --	1-5, 8 9	
A	<u>DE - A1 - 2 925 902</u> (WANZKE) * Page 7, line 14 - page 12, line 24 * --	1-5, 8 9	
A	<u>DD - A1 - 266 864</u> (VEB NUMERIK "KARL MARX") * Totality * --	1-5	TECHNICAL FIELDS SEARCHED (Int. Cl.5)
A	<u>DE - A1 - 3 512 513</u> (VEB KOMINAT UMFORMTECHNIK) * Page 5, line 29 - page 7, line 9; page 7, line 21 - page 11, line 10 * ----	1-5	G 05 B 19/00 B 30 B 15/00
The present search report has been drawn up for all claims			
Place of search	Date of completion of the search	Examiner	
VIENNA	21-03-1991	FIETZ	
CATEGORY OF CITED DOCUMENTS		T : theory or principle underlying the invention E : earlier patent document, but published on, or after the filing date D : document cited in the application L : document cited for other reasons ----- & : member of the same patent family, corresponding document	
X : particularly relevant if taken alone Y : particularly relevant if combined with another document of the same category A : technological background O : non-written disclosure P : intermediate document			

EPO FORM 1501 (01/82) (P0401)

**This Page Blank (uspto)**

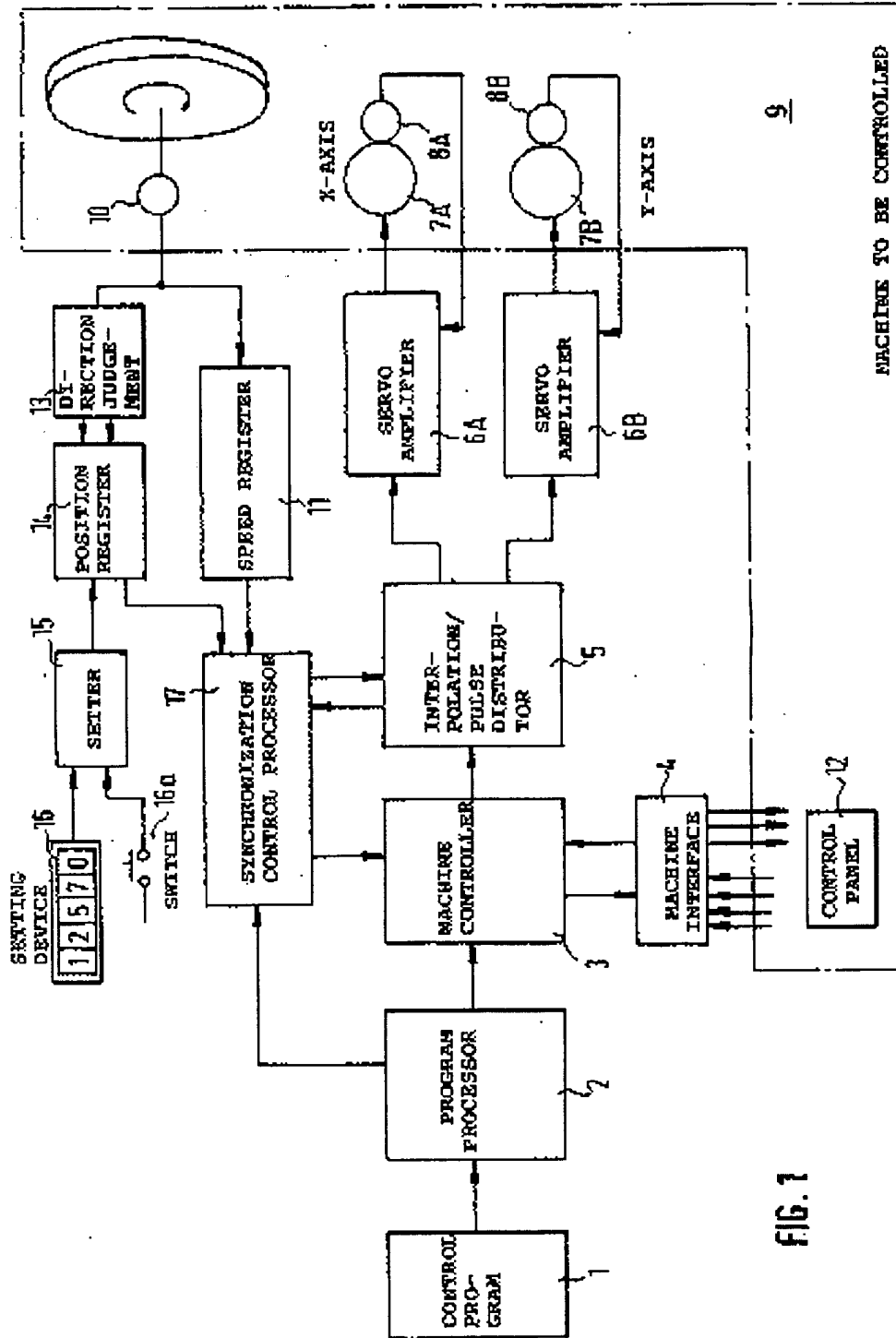

FIG. 1

MACHINES TO BE CONTROLLED

FIG. 1A

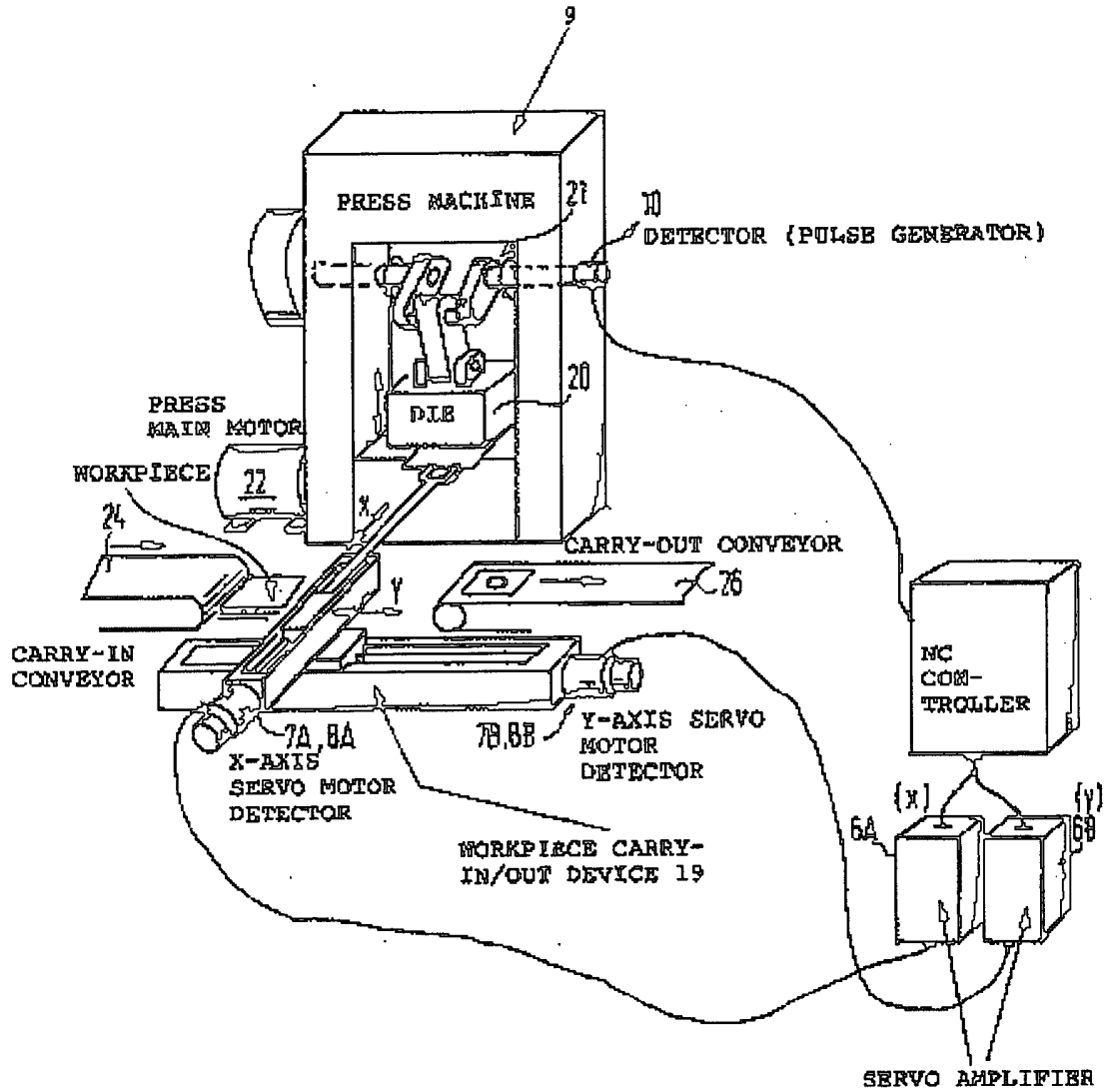

FIG. 2B

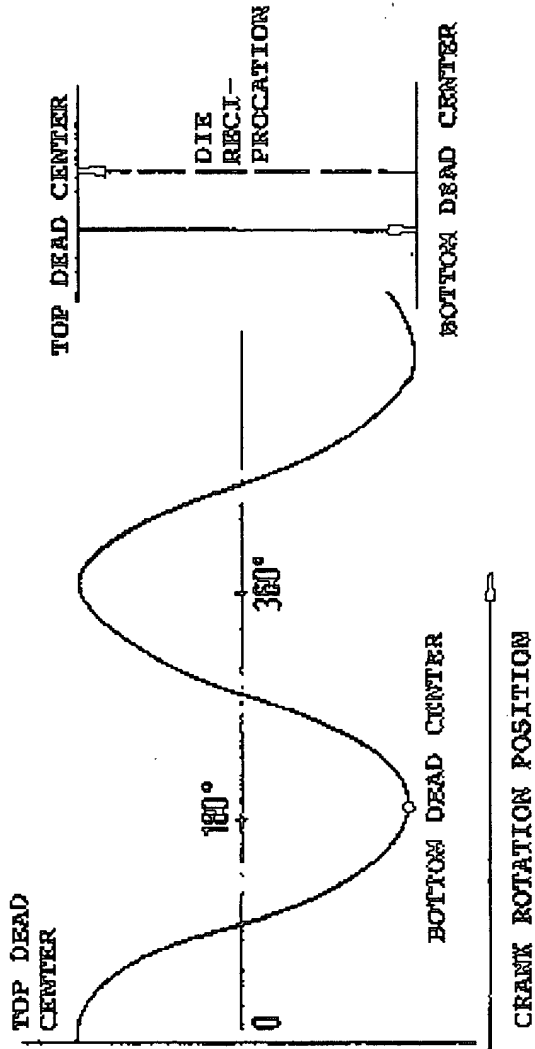
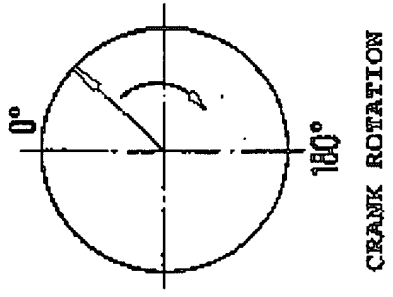
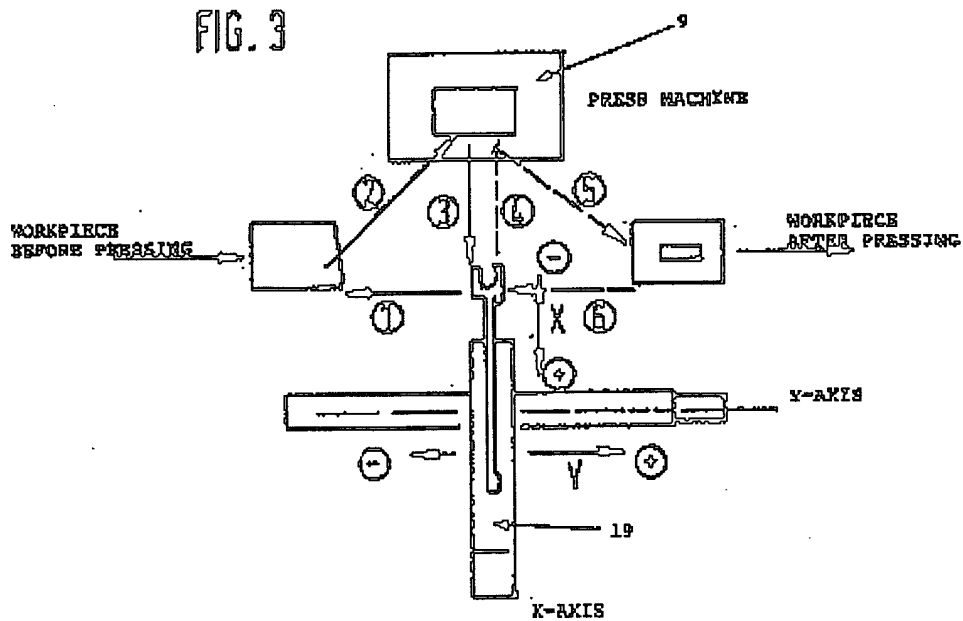
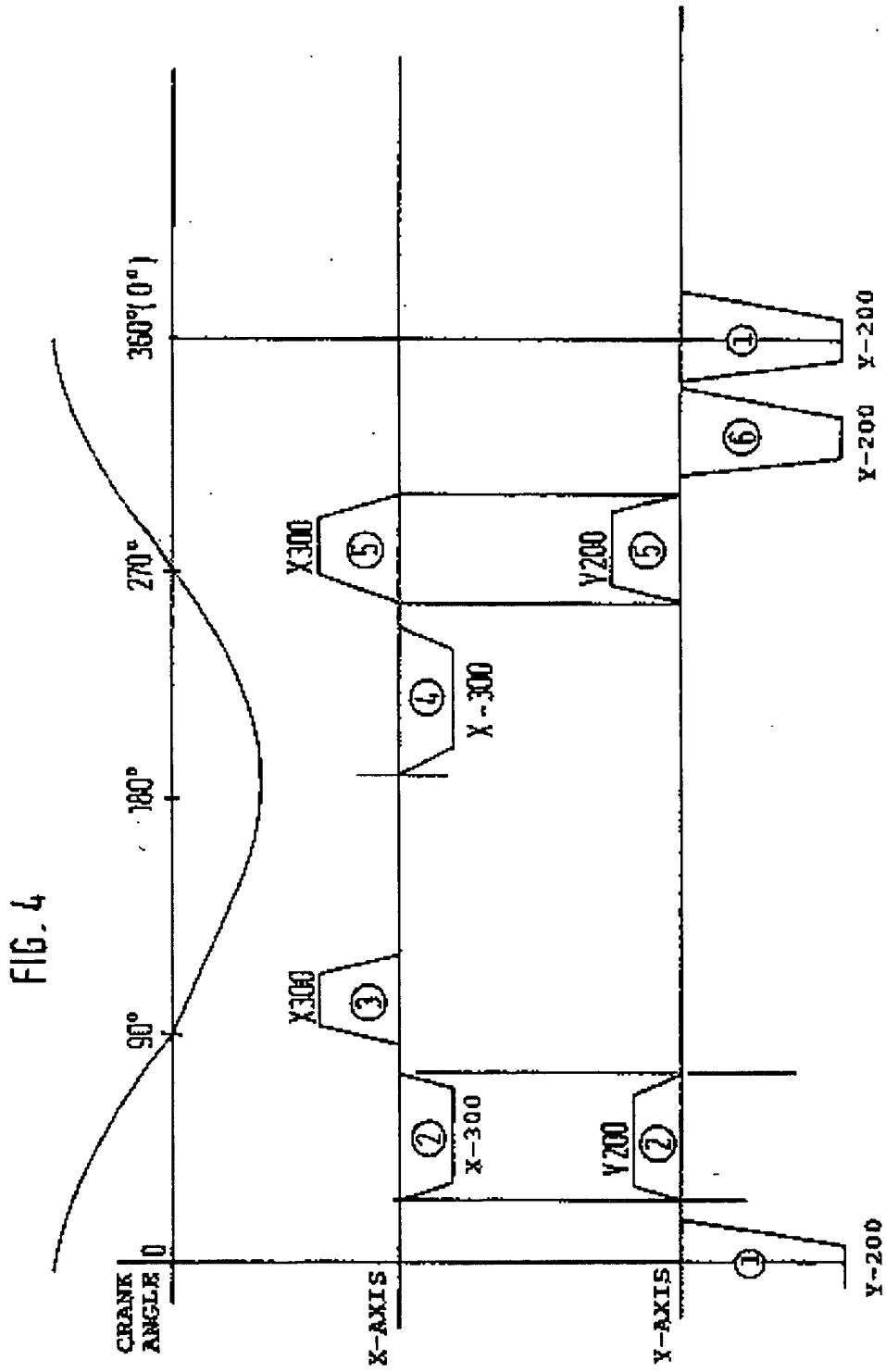

FIG. 2A





PROGRAM STEP	COMMENT
N01 G00Y-200.;	TRAVEL ①
N02 M13;	CLAMP WORKPIECE
N03 G10IG95X-100.Y100.R190.P10.;	TRAVEL ②
N04 M16;	SET WORKPIECE ON PRESS
N05 G95X200.P20.;	TRAVEL ③
N06 G10IG95X-300.R190.P10.;	TRAVEL ④
N07 M15;	CLAMP WORKPIECE
N08 G95X300.Y200.P20.;	TRAVEL ⑤
N09 M16	UNCLAMP WORKPIECE
N10 G00Y-200.;	TRAVEL ⑥
N11 M99;	RETURN TO THE PROGRAM START POSITION



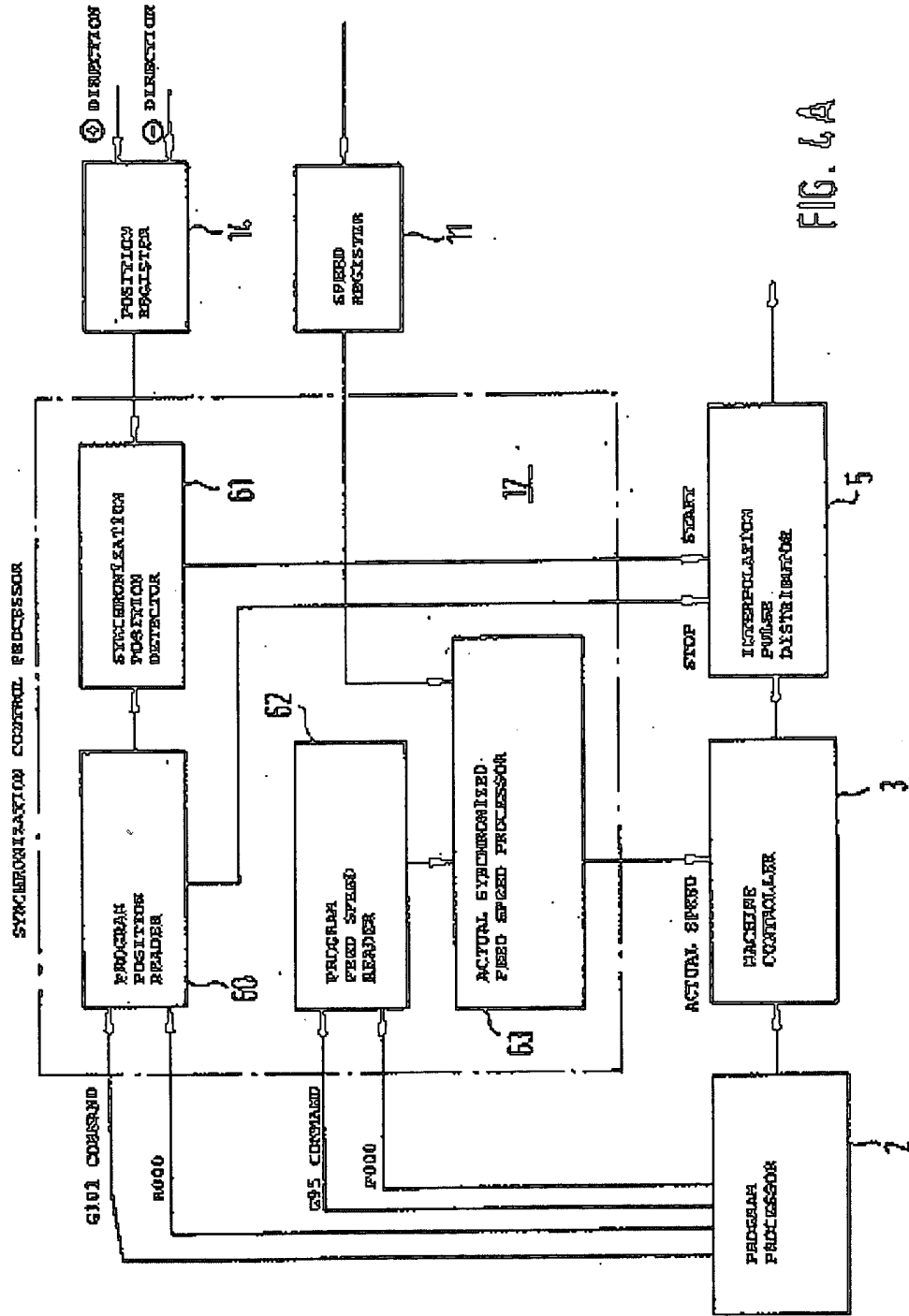

FIG. 6A



FIG. 5

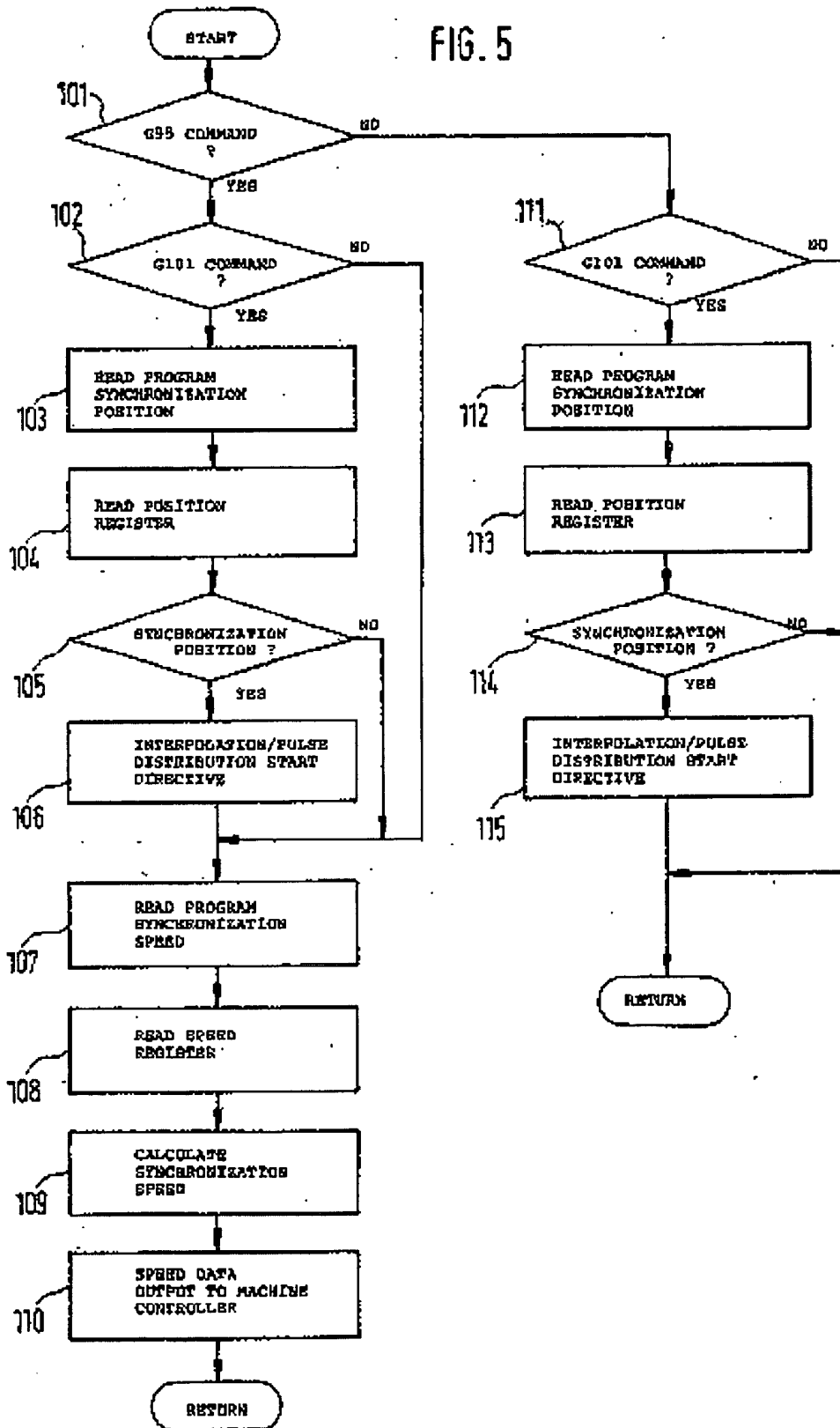
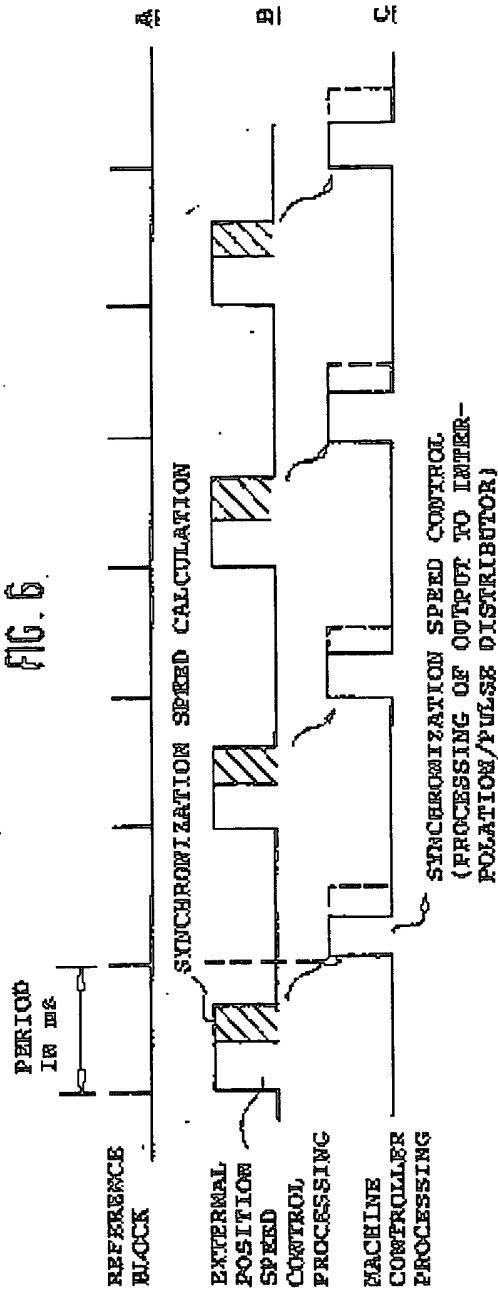

FIG. 6



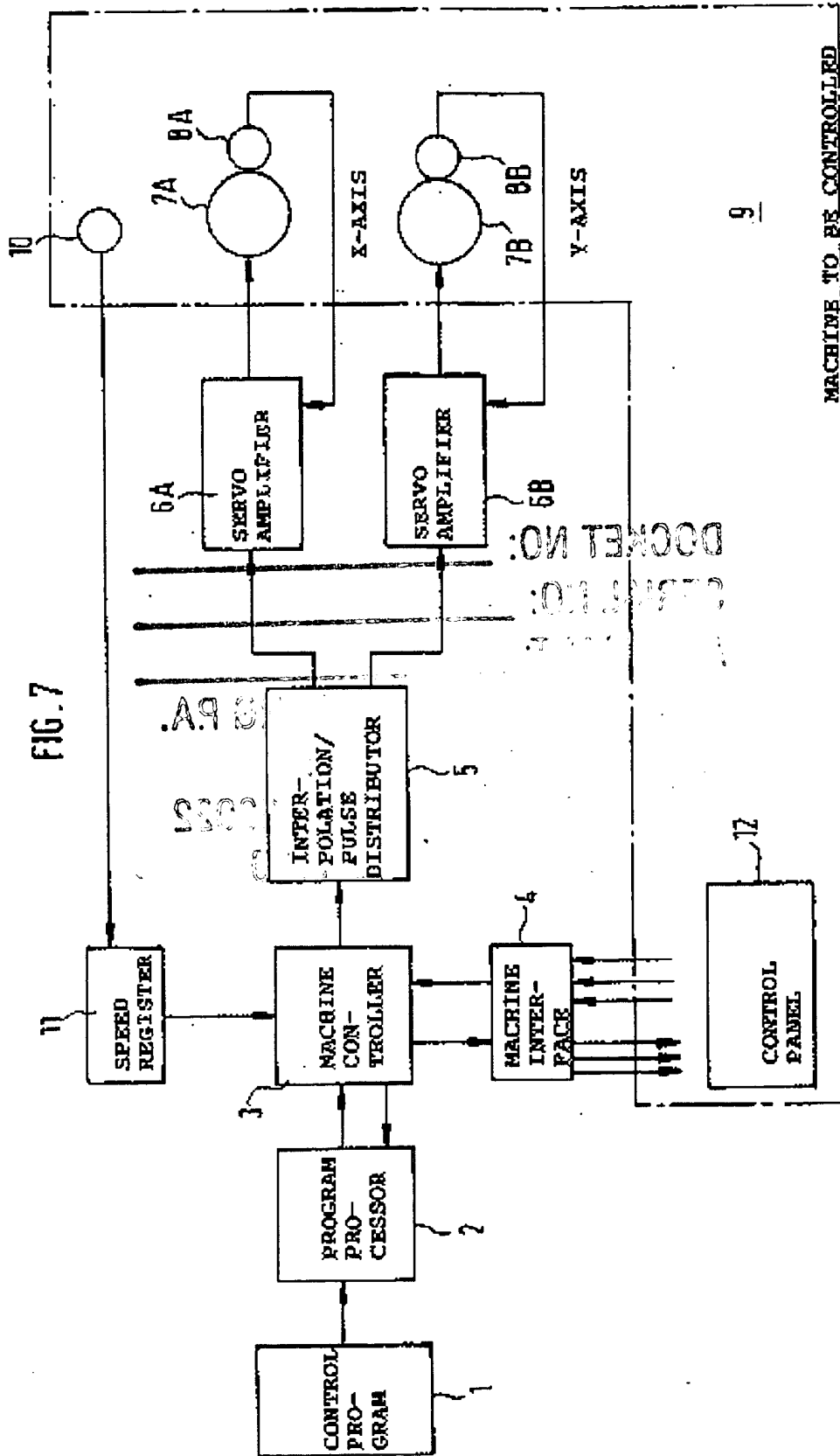

FIG. 7

DOCKET NO: A-2820

SERIAL NO: 09/848, 583

APPLICANT: Matthes et al.

LERNER AND GREENBERG P.A.

P.O. BOX 2480

HOLLYWOOD, FLORIDA 33022

TEL. (954) 925-1100